

荷重元件隔離傳送器 (LOAD-CELL ISOLATED TRANSMITTER)

**MODEL
PWRTL**



特點(FEATURES)

- 精確度0.1%滿刻度 (Accuracy 0.1% F.S.)
- 多種輸入輸出選擇(Wide selection of input/output range)
- 寬範圍交直流兩用電源設計(Wide input range for auxiliary power)
- 尺寸小,穩定性高(Dimension small and High stability)

1:MODEL:PWRTL- (選購型號)

NO	Input Range	NO	Input Range	NO	Exciting Voltage	NO	Output Range	NO	Output Range	NO	Output Range	NO	Aux. Power
1	1mV/V	5	5mV/V	A	5V(<120mA)	A	0-50mV	E	2-10V	I	4-20mA	A	AC/DC 18-60V
2	1.5mV/V	9	SPECIFIED	B	10V(<60mA)	B	0-1V	F	0-1mA	R	SPECIFIED	B	AC/DC 90-260V
3	2mV/V			C	12V(<50mA)	C	1-5V	G	0-10mA				Less 3VA for AC/DC input
4	3mV/V			R	SPECIFIED	D	0-10V	H	0-20mA				

2:SPECIFICATION (主要規格)

- Measuring accuracy : 0.1% F.S. (23 ± 5)
(精確度)
- Exciting voltage : 5V ± 3%(<120mA)
(感應器電源) 10V ± 3%(<60mA)
12V ± 3%(50mA)
- Response time : <250ms (0-90%)
(輸出反應時間)
- Output drive capability : <10mA for voltage mode
(輸出負載能力) <10V for current mode
- Output ripple(p-p) : <0.1% F.S.
(輸出漣波)
- Zero (offset) range : 0- ± 5% F.S.
(歸零調整範圍)
- Span (scale) range : 0- ± 10% F.S.
(最大值調整範圍)
- Temp. coefficient : 100ppm/ (0-50)
(溫度係數)
- Isolation : Input/Output/Power/Case
(隔離特性)
- Insulation Resistance : >100M ohm with 500V DC
(絕緣阻抗)
- Dielectric strength : 2KVac/1 min. (input/output/power)
(絕緣耐壓能力) 1600Vdc (input/output)
- Operating condition : 0-50 (20 to 90% RH non-condensed)
(使用環境條件)
- Storage condition : 0-70 (20 to 90% RH non-condensed)
(存放環境條件)
- Construction : Socket/plugin type with barrier terminals
(安裝方式)

3.Terminal conection(接線圖)

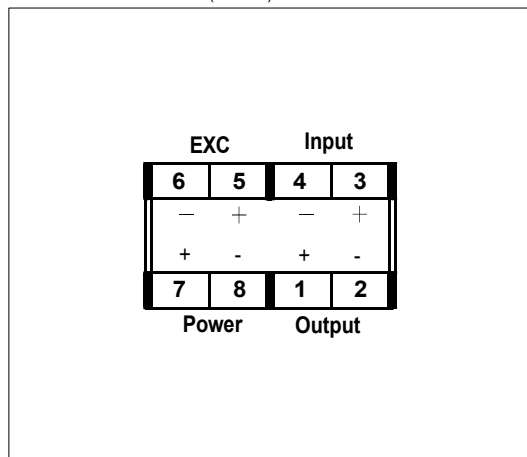

4.Dimension(unit:mm)(外型尺寸)

